

Installation guide

For blockwork, masonry and light steel frame. To ensure correct bracket spacing, size and correct fixings, a FastFrame Project Checklist must be completed and sent to Plastestrip Profiles for calculations.



The project calculations based on the checklist you submit will determine the layout of the single and/or double brackets. Single & double brackets achieve a 80 - 280mm standoff as standard, other sizes are possible and made bespoke. Stand offs greater than 300mm require additional cross bracing and we do not advise having a stand off of greater than 400mm unless being used in a soffit application.



The FastFrame bracket is a three part component that must be used together. This unique design results in much greater fixing centres and therefore, will become more cost effective per metre square than a weaker bracket.

Single bracket reference	Double bracket reference	Potential standoff
FF FIX/BR/65	FF FIX/BRD/65	80 - 105mm
FF FIX/BR/80	FF FIX/BRD/80	88 - 120mm
FF FIX/BR/100	FF FIX/BRD/100	108 - 140mm
FF FIX/BR/120	FF FIX/BRD/120	128 - 160mm
FF FIX/BR/140	FF FIX/BRD/140	148 - 180mm
FF FIX/BR/160	FF FIX/BRD/160	168 - 200mm
FF FIX/BR/180	FF FIX/BRD/180	188 - 220mm
FF FIX/BR/200	FF FIX/BRD/200	208 - 240mm
FF FIX/BR/220	FF FIX/BRD/220	228 - 260mm
FF FIX/BR/240	FF FIX/BRD/240	248 - 280mm

Other bespoke sizes also available

Stand offs of 70 - 80mm are possible using a 40mm leg T rail and the 40mm leg of the angle rail. This must be calculated for as the short bag leg reduces the strength of the spanning rails. Unless otherwise stated, the rails mentioned on the returns sheet are the only ones that have calculated for.

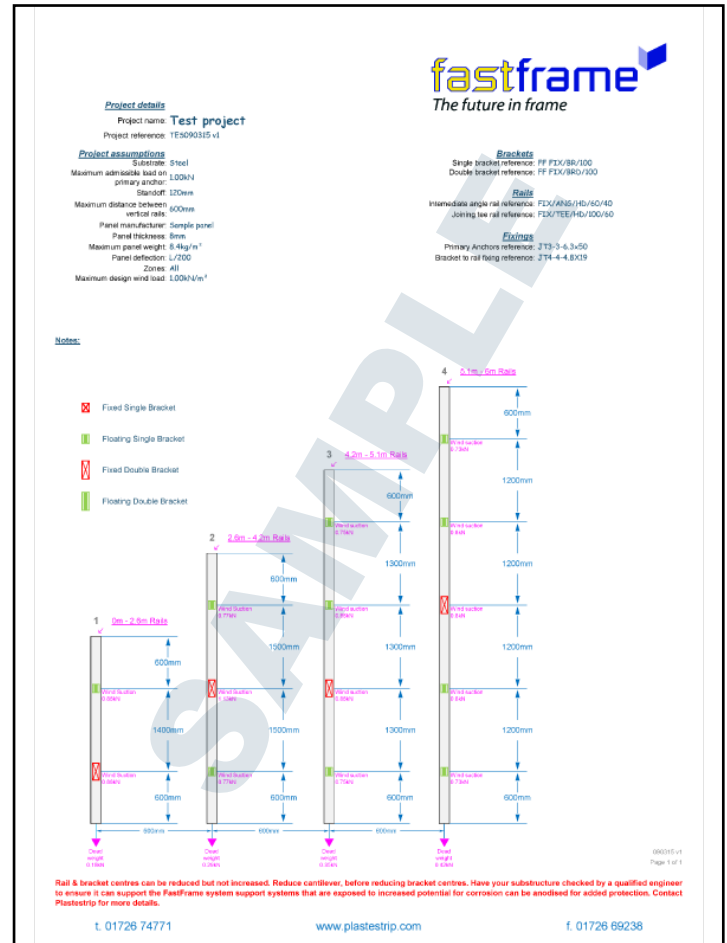

The return sheet you are issued with gives the maximum bracket centres achievable based on the information you have filled in on the checklist. If any values are marked up in red on the checklist or returns sheet then these values have been assumed by Plastestrip and must be verified by the installer / client before installation. Failure to check these values may affect your warranty.

General rules of installation:

- Spans, vertical centres & cantilevers must never be greater than those on your returns sheet.
- A cantilever must never be more than 50% of the span it is adjacent to.
- Rails must always be installed vertically.
- All fixings must be stainless steel and of the same specification or higher than the fixings we have calculated for.

When fixing to masonry or concrete substrates

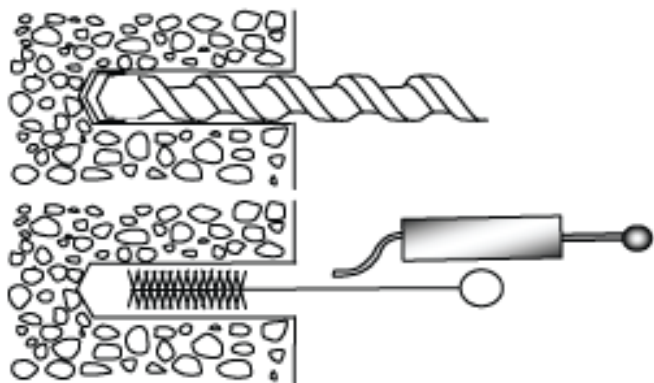

When fixing FastFrame brackets into concrete, a pull out test must be performed to verify the strength of the masonry. All drill holes should be thoroughly cleaned out and free from dust and grit before fixings are inserted.

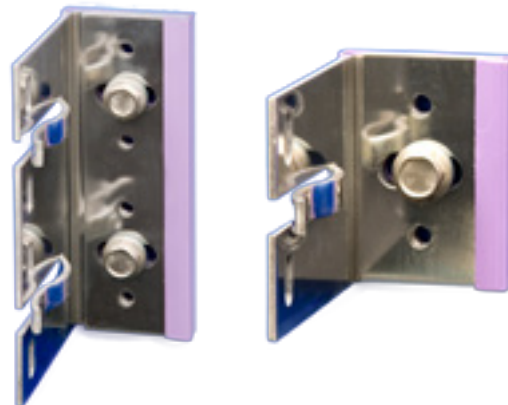

When fixing FastFrame brackets into concrete, ensure the fixings are placed in the larger elongated holes with the collar of the frame anchor plug on the face of the bracket.

When fixing to steel or timber substrates

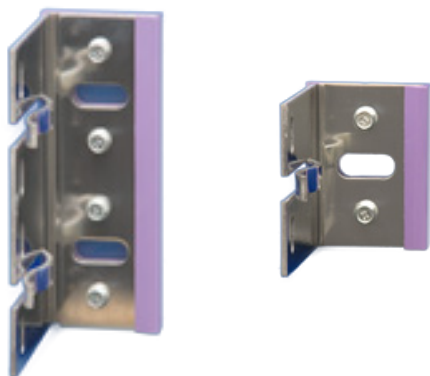

When fixing FastFrame brackets onto steel or timber substrates, please ensure there are 2 anchors per single bracket or 4 anchors per double bracket and that they are placed in the smaller 6.5mm holes.

Fixed and floating point brackets?

An individual rail will usually have only one fixed point bracket and the rest will be floating to allow for expansion. Consult your calculations return sheet for the locations of the fixed and floating point brackets on each rail length range.

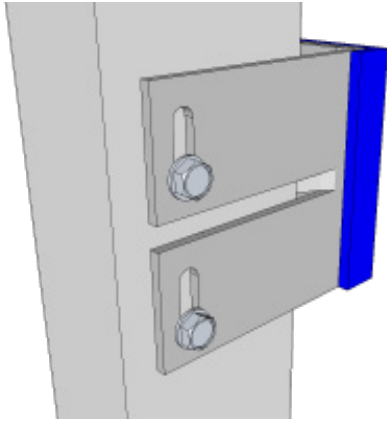

Fixed point bracket

The JT4-4-4.8x19 bracket to rail fixings are positioned at the bottom of the hole to take the vertical deadload of the rail as well as the windload.

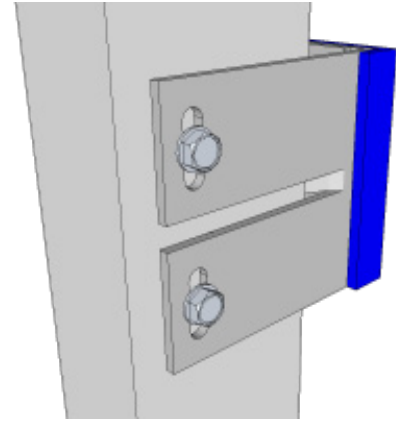

Floating point brackets

The JT4-4-4.8x19 bracket to rail fixings are positioned in the middle of the hole to allow the rails to expand and contract. These brackets only take wind load but minimal deadload.

EVERY SLOTTED HOLE ON THE OUTSTANDING LEG SHOULD BE USED WHEN FIXING RAILS INTO BRACKETS. NO HOLES SHOULD BE LEFT EMPTY.

Tee rails & L rails

RAILS MUST ALWAYS BE INSTALLED VERTICALLY! Although the rails would be fine being installed at an angle, the brackets are not designed to take any side load.

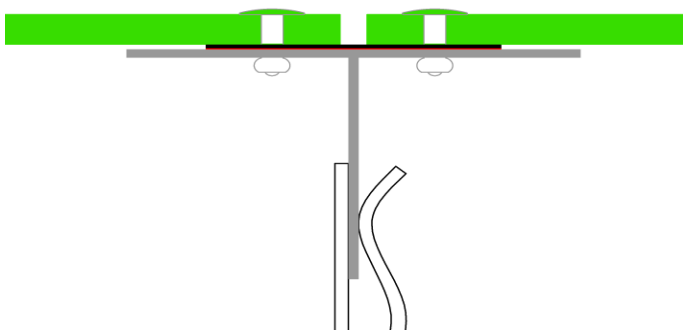

Tee rails

Where vertical joints occur within the cladding facade a Tee Rail should be inserted into the bracket clip.

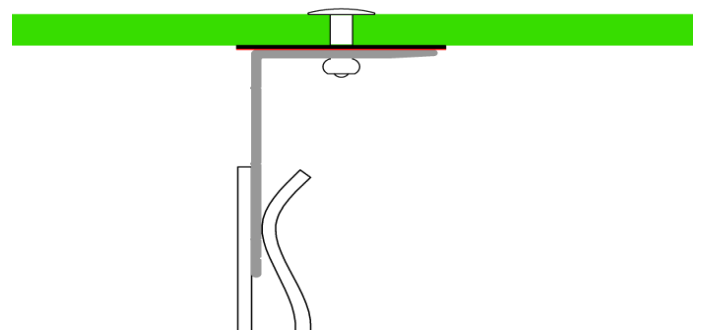

Angle / L rails

Where intermediate panel support is required, insert an Angle Rail. Adjust where necessary. deadload.

Cantilevers & rail joining

An individual rail will usually have only one fixed point bracket and the rest will be floating to allow for expansion. Consult your calculations return sheet for the locations of the fixed and floating point brackets on each rail length range.

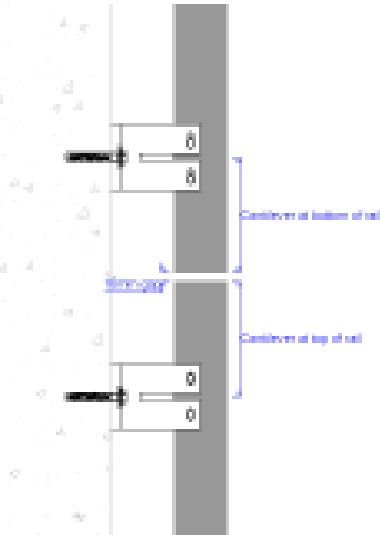

Cantilevers
When you receive your bracket spacings back from us, they will dictate how much the rail can sail past the bracket. There **MUST ALWAYS** be a 10mm gap between rails going up the facade. Panels **MUST NEVER** span over rail joints. Support rails **SHOULD NEVER** span over the buildings movement joints unless specifically engineered to do so.



Rail joining
If you wish to join two rails together using a bracket then you can but bear in mind that joining on a double bracket is the same as having a single bracket at the end of each rails. If your calculations specify a double bracket at the end of the rail then you cannot join them in this way.

Insulation with framing systems

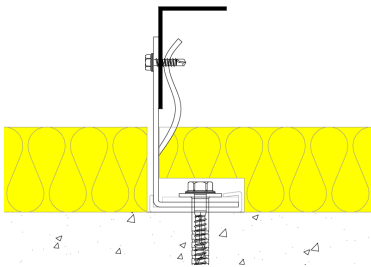

The insulation does not interfere with the rails or fixings

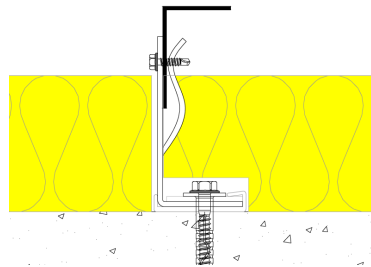

The insulation will have to be cut away to allow the leg of the rails to be fitted but will not affect the fixing of the rail to the bracket.

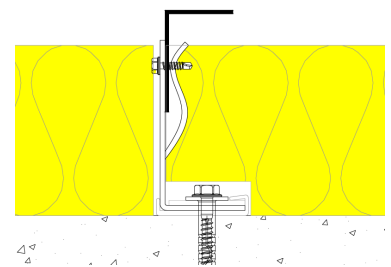

The insulation will have to be cut away to allow the leg of the rails to be fitted and the rail to bracket fixing is under the surface of the insulation making it very hard to fit.

Cross bracing for large a cavity

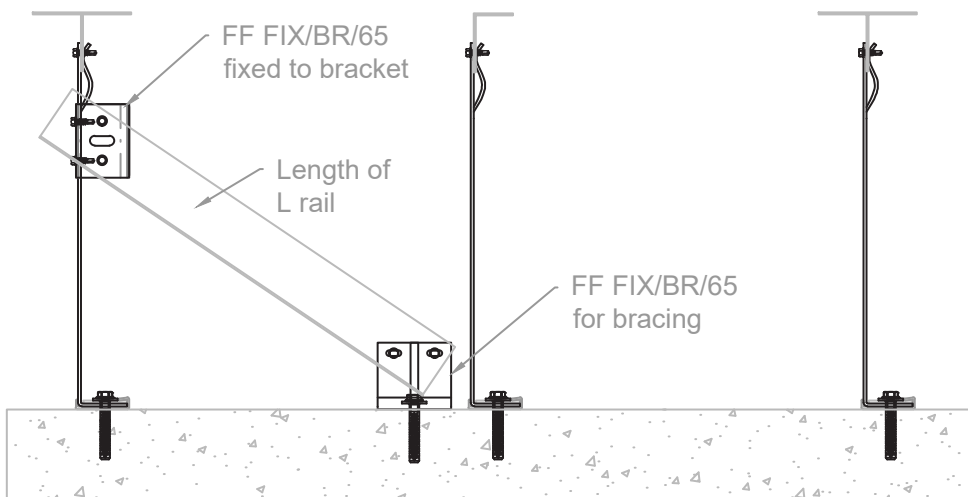

All stand offs greater than 300mm should be cross braced as per the detail shown here. This needs to be on the top and bottom bracket of one rail every 3m going across the facade. We do not advise that you

As a guide, for a wall 3m high and 12m wide you will require and extra 20 x 65mm brackets and a 10 x short lengths of angle rail to brace. (this equates to